

# STREET SPRINKLER



## Main Parameters

Items		FLM5180GQXDLBEVS	FLM5250GQXDFBEVS
GVW	kg	18000	25000
Wheelbase	mm	5300	5000+1350
Payload Weight	kg	8615	11170
Upper Weight	kg	1690	2300
Max Speed	km/h	88	90
Selectable Of Chassis Brand		DONGFENG	DONGFENG
Sprinkler Pump Model		65QZB-50/110N	65QZB-50/110N
Sprinkler Pump Flow	m <sup>3</sup> /h	50	50
Rear High Sprinkler Range	m	≥50	≥50
Washing width	m	≥24	≥24
Water Tank Effective Volume	m <sup>3</sup>	9.04	11.72
Power Type		BEV	BEV
Endurance Mileage	km	260	250
Total Electricity Storage Capacity	kWh	218.54	314.14

## Spray Nozzle

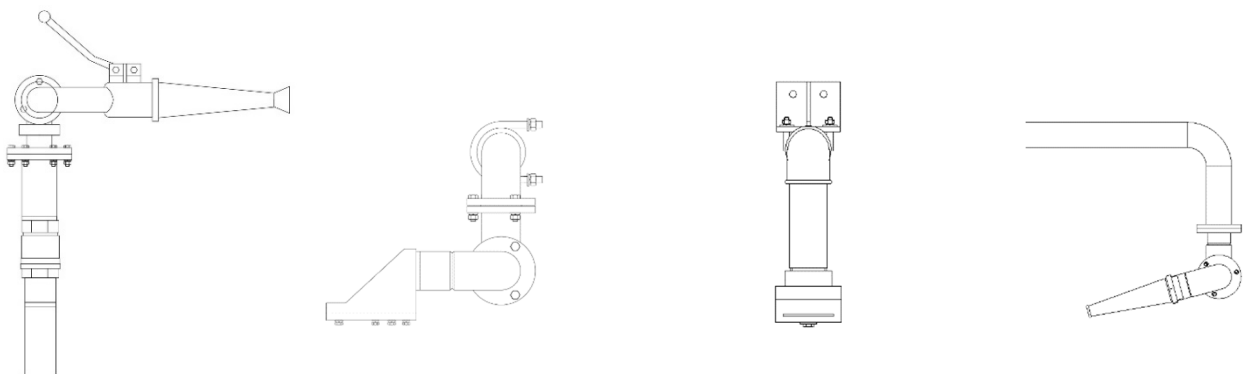

# Base Specification

## Cleaning device:

- The spray gun located at the rear of the car body is flexible in operation and has a wide range of working angles. It can be used to spray and wash objects of various heights, and can remove some dead angles of sanitation that are not easy to clean. The utility model also has the auxiliary fire fighting function, and the high water spray gun can be adjusted into a column shape or a mist shape.
- Equipped with left middle column side punch and right rear column side punch, the nozzle can be 360 ° left and right, 360 ° up and down.
- The rear bumper is equipped with two sprayers, which are used for daily watering, humidification and dust reduction.

## Safety:

- The water tank is equipped with a low water level sensor alarm system, which can automatically alarm when the water level is low, so as to prevent the water pump from being damaged due to water shortage.

## Water pump:

- The self-priming two-stage centrifugal pump is adopted, the pump is driven by the power of chassis engine, and the low level flushing mode which is the first in China is adopted.

## Control system:

- High reliability and pollution-free advanced pneumatic system is adopted for the whole vehicle operation, and all road operation functions can be operated in the cab.

## Body:

- The switch control valve parts and sprinkler system pipes are made of corrosion-resistant materials, the water storage tank is made of high-strength steel plate, and the inside is treated by special process without corrosion.
- The structure layout is compact and reasonable, the volume of water tank is large, and the working time is long.

## Optional device:

- Stainless steel tank can be selected.
- Rear (upper and lower) low pressure spray electric control.
- Left and right side watering device.
- Self-priming device.
- 10M (22I hose) homemade winch with homemade car washing gun.
- A water inlet (fire hydrant interface) is installed on the top.
- Snow melting mixing device.
- Stainless steel low pressure pipeline.
- Rear stainless steel high pressure spray.
- Stainless steel low pressure water pump (Model 80QZB-60/90N).
- Low pressure single point desilting device.
- Widening platform.
- Front automatic water cannon.