

PAVEMENT MAINTAINING TRUCK



Main Parameters

Items		FLM5040TYHDCBEV
GVW	kg	4300
Wheelbase	mm	3000
Payload Weight	kg	1550
Upper Weight	kg	770
Upper Transportation Dimensions	mm	2900×1650×2480
Selectable Of Chassis Brand		SAIC/DONGFENG
High Pressure Water Pump Model		CC 34/17S
High Pressure Water Pump Pressure	MPa	17
High Pressure Water Pump Flow	L/min	34
Water Tank Volume	m ³	1.8
Cleaning Width	m	≥1.5
Front Sprayer Pressure	MPa	≥9
Power Type		BEV
Endurance Mileage	km	220
Total Electricity Storage Capacity	kWh	48.97

Spray Nozzle

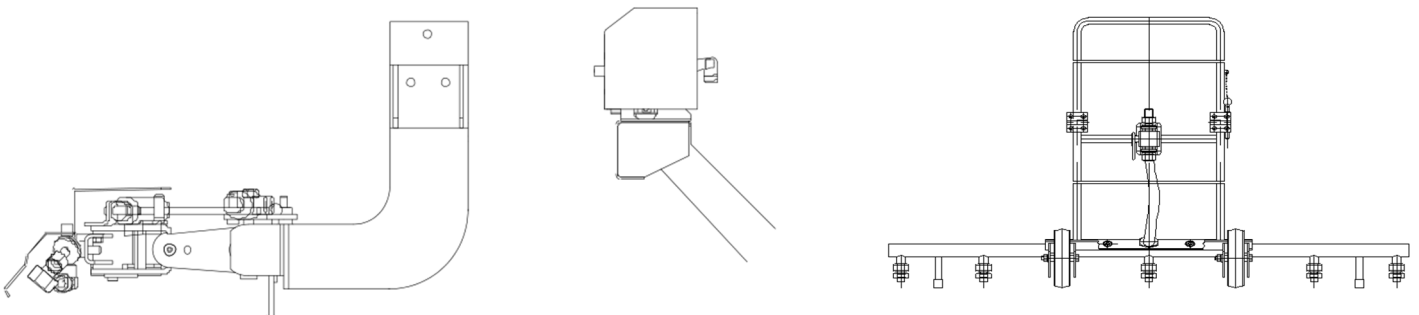

Base Specification

Water pump:

- The high-pressure water pump of the model adopts stepless speed regulation, which can adjust the speed of the high-pressure water pump in the cab according to the road conditions, and extend the working time and improve the endurance under the premise of achieving the cleaning effect.
- High pressure and small flow inlet pump, strong jet water flow, long continuous operation time.

Body:

- The water tank is made of integral type, with strong seismic resistance and no deformation. The water tank is equipped with a low water level sensor alarm device to prevent the high-pressure water pump from being damaged due to water shortage.
- In order to adapt to the harsh working environment, all fasteners are galvanized. All structural parts are acid pickling and phosphating, outdoor resin powder, high temperature electrostatic spraying process, strong adhesion, corrosion resistance, weather resistance, strong corrosion resistance.

Spraying water frame:

- The hand push nozzle cleaning device can clean the road surface and blind joint in the area where the vehicle cannot pass by using the high pressure and small flow cleaning water curtain ejected by the high pressure nozzle. The device adopts foldable structure, which is convenient, fast, water-saving and environmental protection.

Chassis:

- This vehicle adopts the pure electric technology route: that is, the chassis drive motor is used to drive the whole vehicle and the high-pressure water pump drive motor is used to drive the high-pressure water pump. The energy source of the whole vehicle is lithium-ion power battery.

Cleaning device:

- The cleaning device is composed of a front cleaning device, a column single point cleaning device, a manual spray gun device, a manual push spray pipe cleaning device, etc. the cleaning function is diversified, which can meet the cleaning and maintenance work of roads with different degrees of pollution.
- When the front cleaning device works, the high-pressure water flow can form a complete cleaning plane. The electric hydraulic cylinder rotates 12° up and down, and the left and right sways 20° respectively. The cleaning effect is good.
- The operation of the column single point cleaning device is all electric control, and the driver can complete the operation in the cab. The utility model can swing up, down, left and right in all directions, which is suitable for the removal of local health dead angle of the road.
- The manual high-pressure spray gun, equipped with 20 meters long hose, wide range of operation. In order to cope with various working conditions, four kinds of professional nozzles are also equipped, which are the key to street advertisements.

Monitoring device:

- Front down view camera, color LCD in the cab, observe the road condition and cleaning effect at any time.

Other advantages:

- The car is also equipped with a light, small and water broom with anti sputter protection cover, and the rotary nozzle is better for cleaning. It can clean and sweep the rest stool, narrow platform, wall and other areas on the road.

Optional device:

- The vehicle can also choose a variety of practical devices according to the actual operational requirements, such as cooling and dustfall, adjusting the air humidity of the rear spray device and the rear spray device; and the side wash fence device with large current, high pressure and anti-collision function.
- Back down high-pressure hedge.
- Pneumatic pipe cleaning device (air blowing device).
- Imported long car washing gun.
- Manual universal wheel spray frame.