

GUARDRAIL CLEANING TRUCK



Main Parameters

Items		FLM5070GQXQL6H
GVW	kg	7300
Wheelbase	mm	3360
Payload Weight	kg	2690
Upper Weight	kg	2330
Upper Transportation Dimensions	mm	4020×2120×2480
Working Speed	km/h	2~10
Selectable Of Chassis Brand		ISUZU
High Pressure Water Pump Model		NX-C75/150
High Pressure Water Pump Pressure	MPa	15
High Pressure Water Pump Flow	L/min	75
Water Tank Volume	m ³	4
Cleaning Height	mm	120~1400
Cleaning Thickness	mm	0~200

Technical Specification

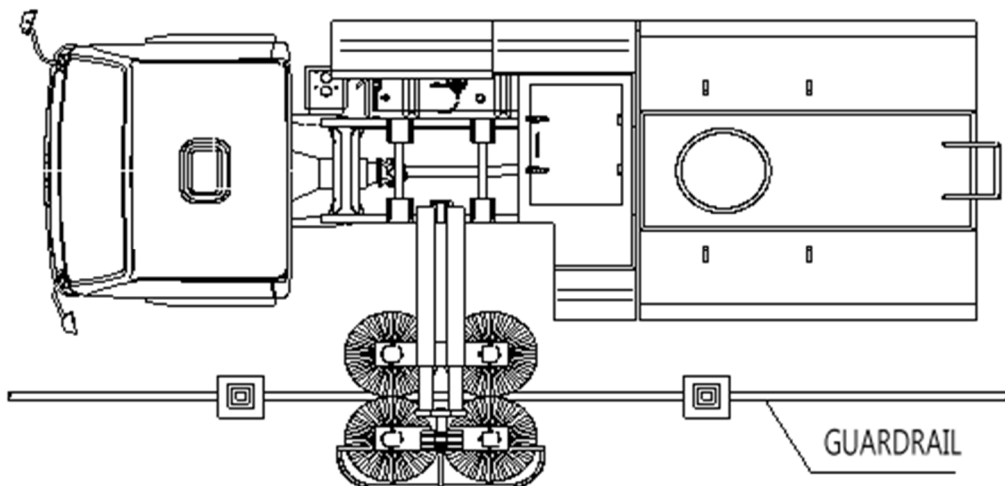

Base Specification

Cleaning function:

- Adopt double-sided cleaning device, four groups of rolling brush clamping isolation guardrail rotating washing, high-pressure water assisted washing and electro-hydraulic control operation mode to clean the isolation guardrail, so as to ensure all-round cleaning of the isolation guardrail without dead angle.
- Set two working modes of low-pressure water cleaning and high-pressure water cleaning. The corresponding working mode can be selected according to the cleanliness of the isolation fence, so as to achieve longer working time and more economic operation efficiency.
- The swinging arm type guardrail cleaning device is used. During the operation, the guardrail cleaning device can be operated with one key to extend and lower in place, which makes the operation of the driver more convenient and quick.
- Add felt strip bristles to roll broom brush, increase the contact area during cleaning, ensure comprehensive cleaning and isolation of guardrail, and avoid damaging the paint surface of guardrail.

Hydraulic system:

- The hydraulic system is equipped with hydraulic oil cooler and hydraulic oil level alarm device, which improves the reliability and safety of the equipment and ensures the continuous and efficient operation of the guardrail cleaning car.

Control system:

- The auxiliary engine clutch adopts the program-controlled automatic clutch, with humanized operation, effectively extending the service life of the auxiliary engine.
- Adopt intelligent control system, centralized control of electrical system and hydraulic system, simple operation, and the driver can complete various actions in the cab.

Other function:

- The camera is used to real-time monitor the rolling and washing barrier, and the display screen is installed under the front windshield of the driver's seat, so that the driver can know the cleaning condition of the barrier in real time and ensure the working effect of the barrier cleaning vehicle.
- The guardrail cleaning mechanism return alarm device is set to ensure the safety of the vehicle during the transfer operation.
- The safety interlock device of guardrail cleaning mechanism is adopted to improve the safety of operation, even if the driver mis operates, the mechanism will not be damaged.

Optional device:

- The right guardrail cleaning device can be selected with the same cleaning performance as the left guardrail.
- Cleaning double yellow line (with manual control)
- Rear spray (first electronic control, manual control).
- Front corner spray offset (manual control).
- Automatic winch (with 20m 10I rubber tube).